

SECTION A-A

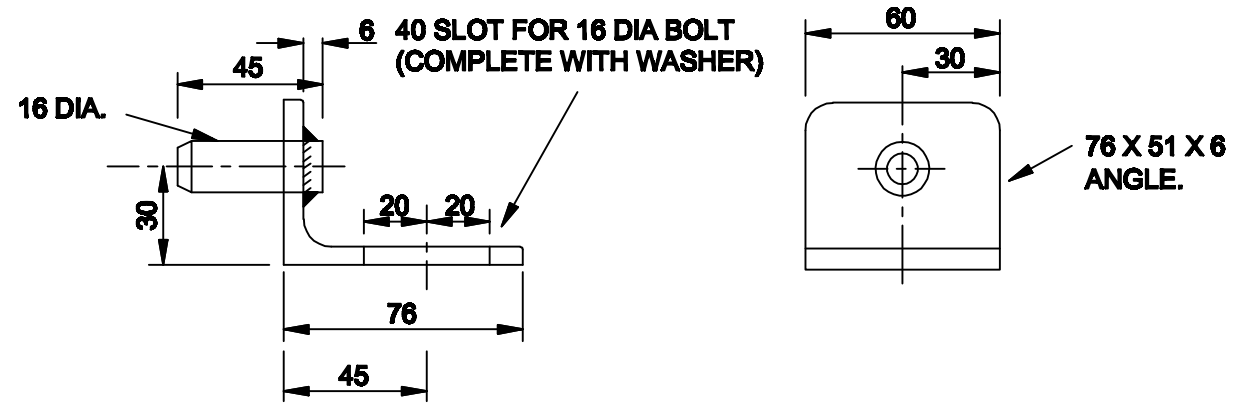

DETAILS OF SWIVEL PIN BRACKET  
(SECURED TO PLATFORM WITH 16 DIA BOLT)

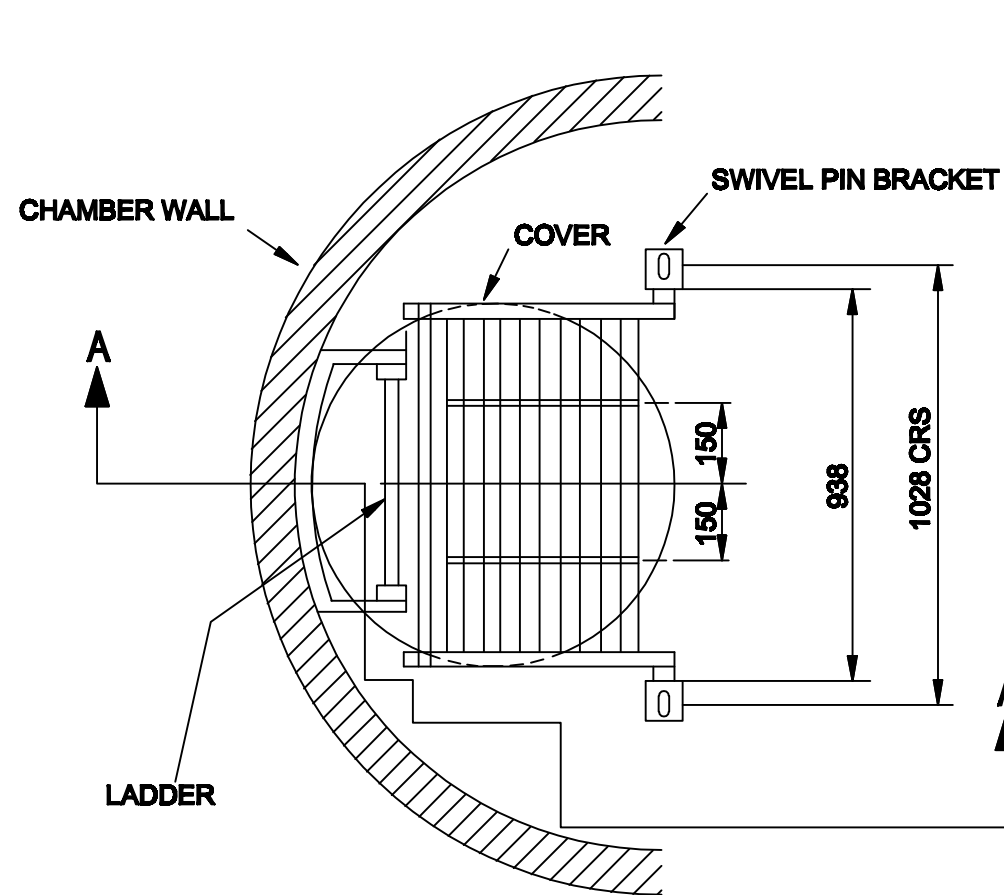

ASSEMBLY PLAN

(PLAN DETAIL ON GRATING POSITIONED ON LANDING SLAB)

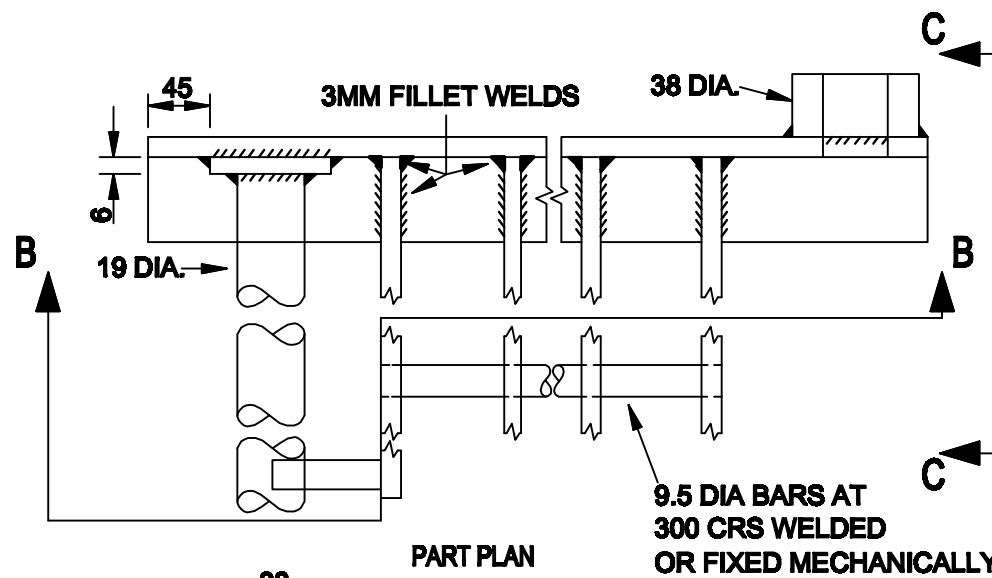

PART PLAN

9.5 DIA BARS AT 300 CRS WELDED OR FIXED MECHANICALLY.

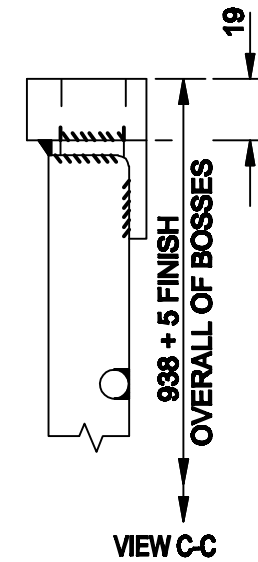

VIEW C-C

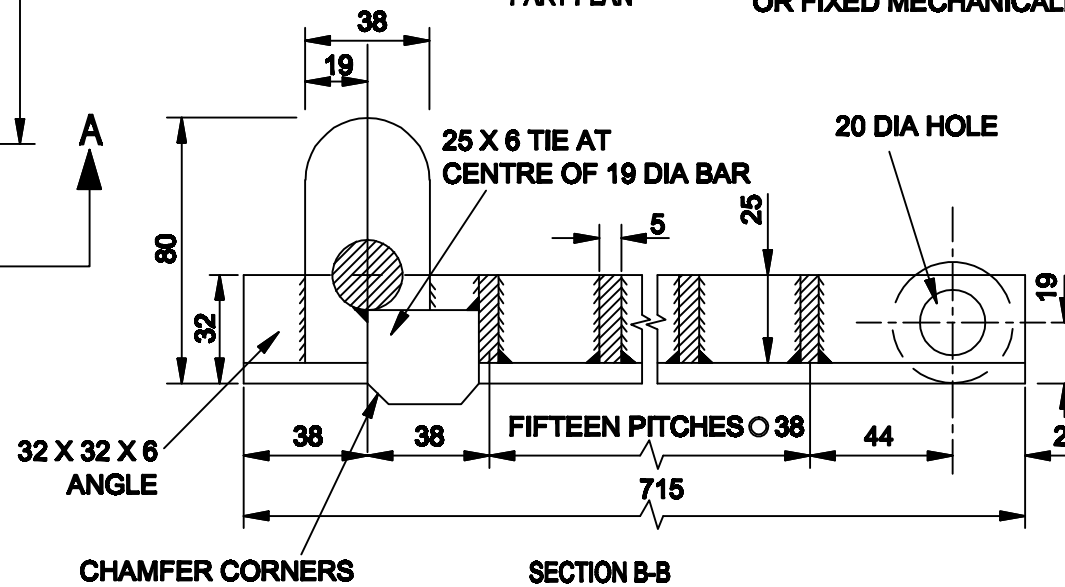

CHAMFER CORNERS

SECTION B-B

NOTES:

1. ALL DIMENSIONS ARE IN MILLIMETRES.
2. ALL WELDS ARE TO BE 6MM FILLET WELDS EXCEPT WHERE STATED OTHERWISE.
3. THE GRATINGS AND BRACKETS ARE TO BE FABRICATED FROM STEEL TO BS 970 : PART 1 AND TO BE PROTECTED BY HOT DIP GALVANIZING.

| Rev : | Remarks :         | Drawn :     | Date :     | Title : |
|-------|-------------------|-------------|------------|---------|
| A     | Issued drawing.   |             | April 2003 |         |
| B     | Change Logo to TM | E. Farrugia | March 2014 |         |