

SECTION Y-Y

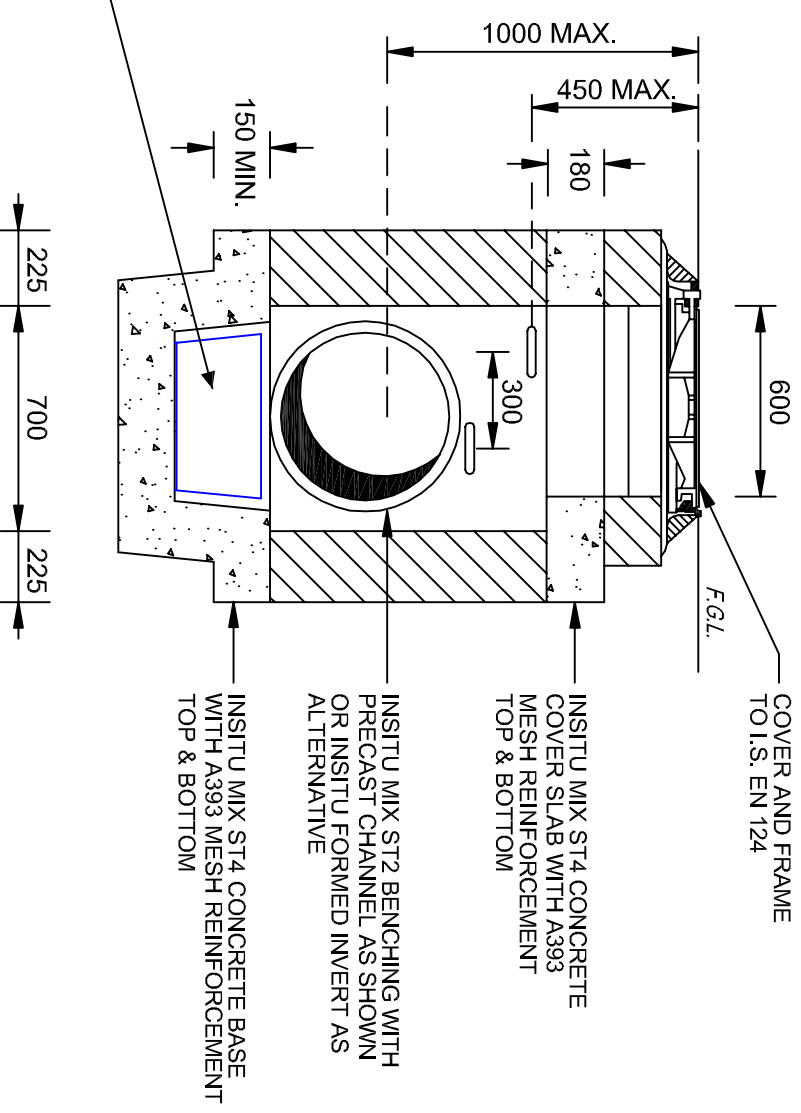

SECTION X-X

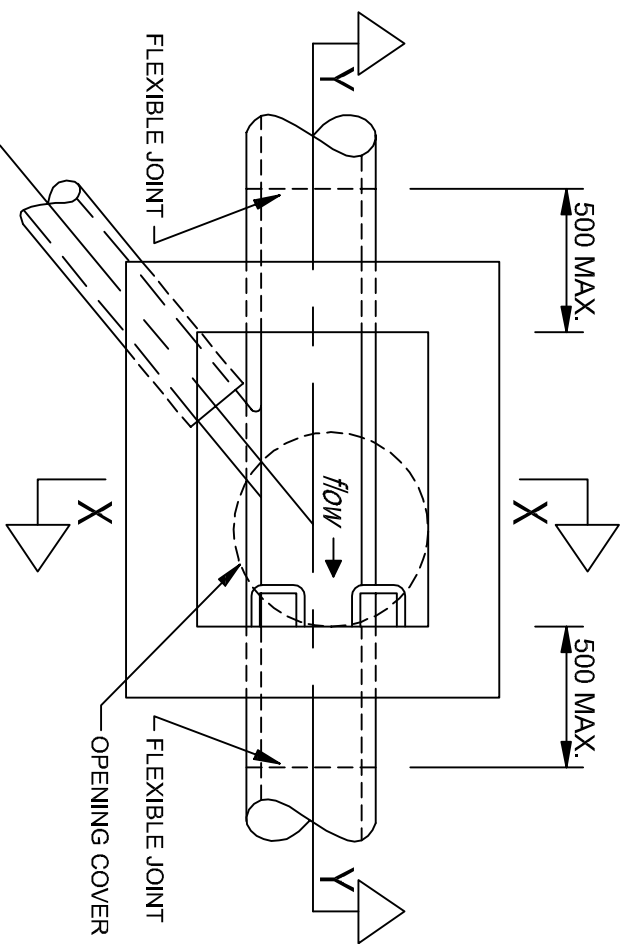

SECTIONAL PLAN ON STRAIGHT INVERT

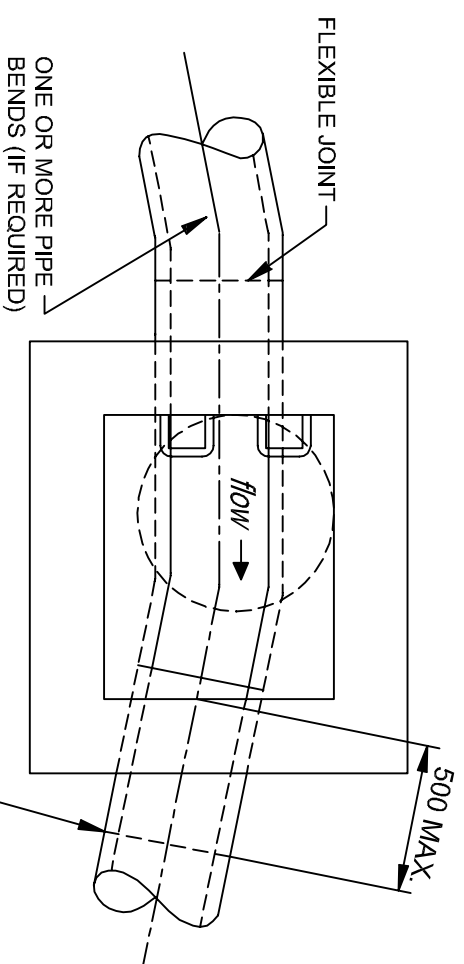

SECTIONAL PLAN ON CURVED INVERT

- NOTES**
1. ALL DIMENSIONS ARE IN MILLIMETERS.
  2. MANHOLES TO BE CONSTRUCTED IN 21N CONCRETE BLOCKS WITH DESIGNATION 1 MORTAR AND TO SERIES 2400 OR IN-SITU MIX ST4 CONCRETE.
  3. FOR INVERT DETAILS, NUMBER OF BRANCHES, DETAILS OF PIPES, TYPE OF COVER AND FRAME, SEE THE DRAINAGE SCHEDULE.
  4. MANHOLE OPENING TO BE FURTHEST FROM THE NEAREST CARRIAGEWAY AND MANHOLE STEPS POSITIONED TO ALLOW VIEWING ONCOMING TRAFFIC.
  5. CHAMBERS ON FOUL SEWERS TO BE PLASTERED.

Rev :	Remarks :	Drawn :	Date :
-	Issued drawing.	M. Borg	April 2003
A	Change Logo to TM	H. Galea	March 2010
B	Included Silt Bucket		Aug. 2012