

NOTE:
All dimensions are nominal

NOTE:
All dimensions are nominal

INTERLOCKING WIRE FASTNER
OVERLAPPING RING WIRE FASTNER
(Not allowed for basket to basket connection)
ALTERNATE TYING FASTNERS

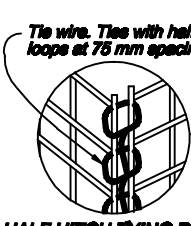
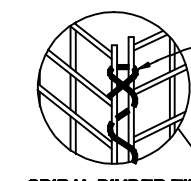
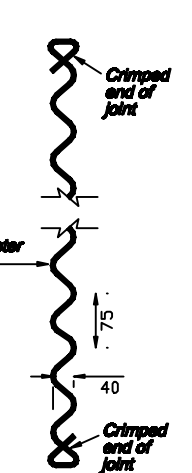

SPIRAL BINDER 3.76 mm DIA.

HALF HITCH TYING DETAIL
(Welded wire mesh)

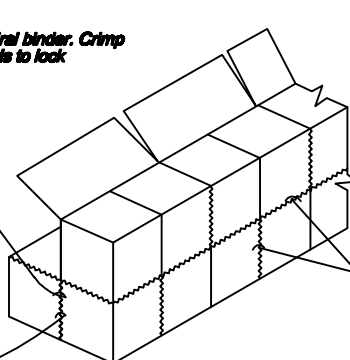

TYPICAL INSTALLATION
GABION BASKETS

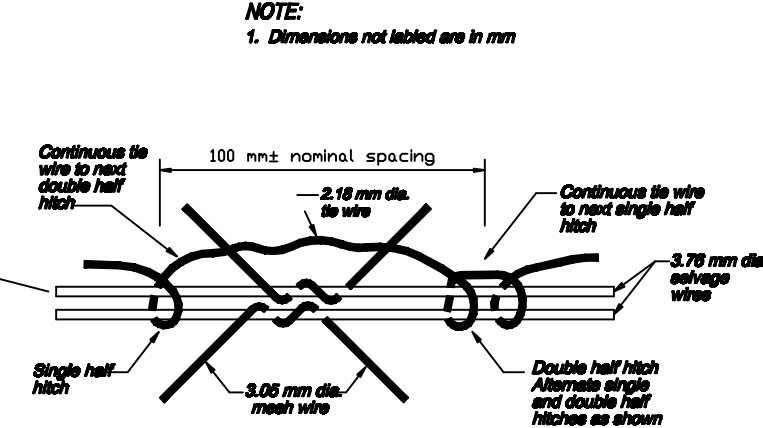

HALF HITCH TYING DETAIL
(Twisted wire mesh)

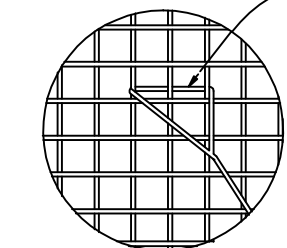

WELDED WIRE MESH

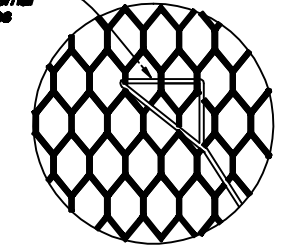

TWISTED WIRE MESH

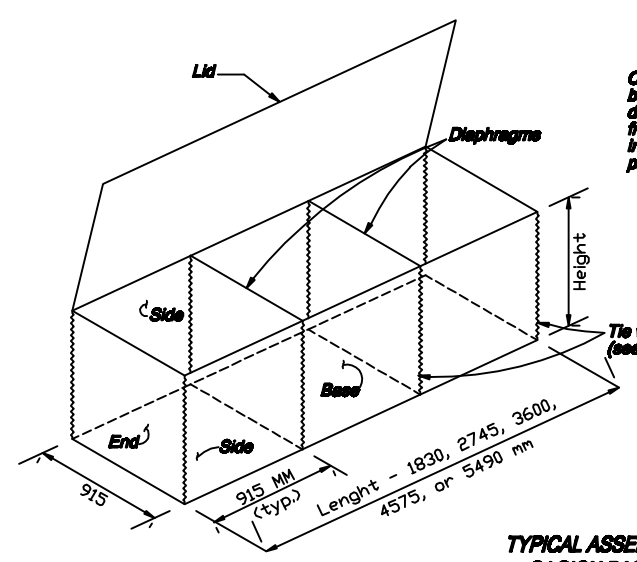

TYPICAL ASSEMBLED
GABION BASKET

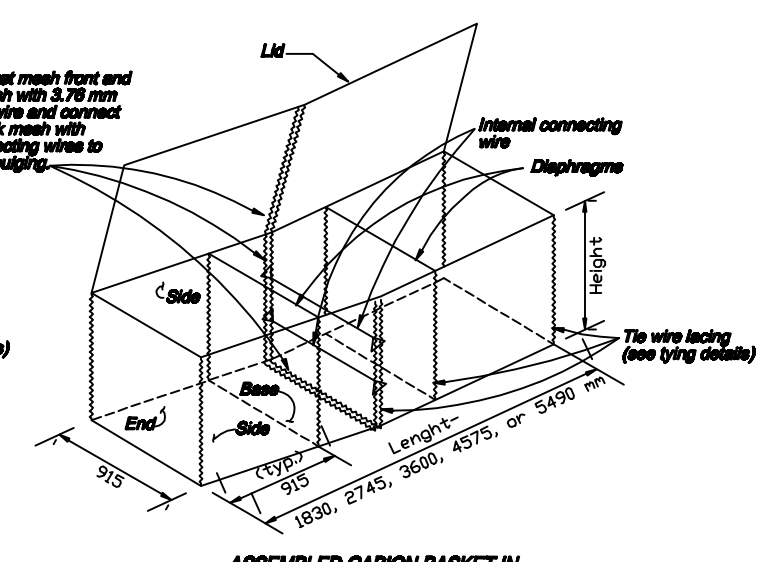

ASSEMBLED GABION BASKET IN
WALL GRADE TRANSITION AREAS

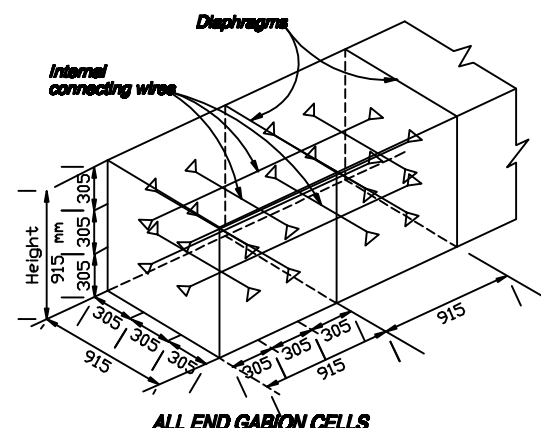

ALL END GABION CELLS

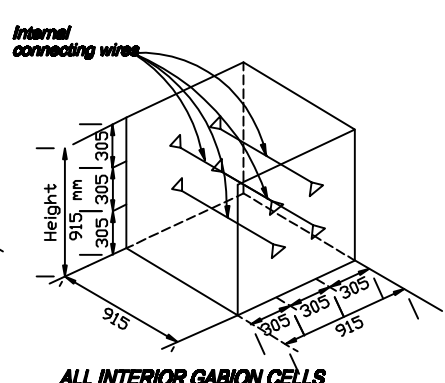

ALL INTERIOR GABION CELLS

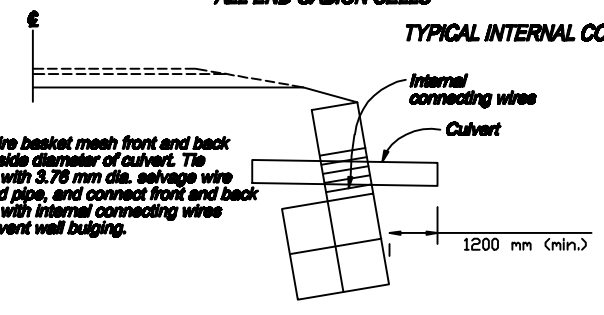

TYPICAL INTERNAL CONNECTING WIRES

NOMINAL SIZES AND CAPACITY OF GABION BASKET				
Size Code	Size in metres		Diaphragm Partions	Capacity m3
	Length	Height		
A	1.83	0.915	1	1.5
B	2.75	0.915	2	2.3
C	3.66	0.915	3	3.1
X	4.58	0.915	4	3.8
Y	5.49	0.915	5	4.6
D	1.83	0.45	1	.08
E	2.75	0.45	2	1.1
F	3.66	0.45	3	1.5
G	1.83	0.30	1	0.5
H	2.75	0.30	2	0.8
I	3.66	0.30	1	1.0

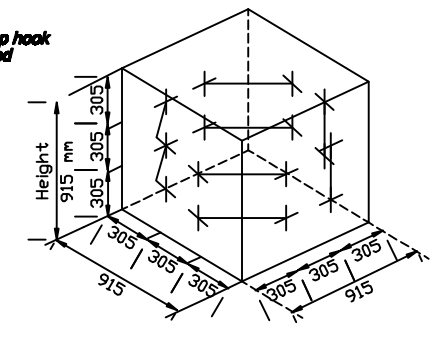
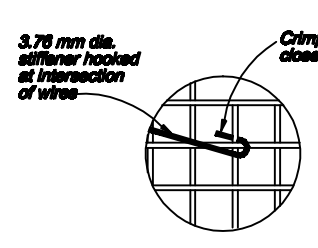

ALL GABION CELLS
OPTIONAL INTERNAL CONNECTING WIRES
WELDED WIRE GABION BASKET